

XYP 1: Pneumatic test unit

For performing functional tests on *centair* peripheral equipment and fault-finding in plants with *centair* control facilities. The following can be tested: supply pressure p_1 , actual value p_3 and p_4 , command variable p_5 , remote adjustment of setpoint p_6 . The output pressure p_2 is simulated. Conforms to the regulations on pressure equipment (97/23/EG Art. 3.3).

Housing and insert of thermoplastic (no front door); front plate with adjuster knob for the output pressure and six M4 measurement connections; compressed-air connections Rp 1/8, female thread.



Type	Description	Weight kg
XYP 1 F001	<i>centair</i> test unit	0.7
Supply pressure p_1 ¹⁾	1.3 ± 0.1 bar	Connection diagram A03207
Output pressure p_2	0...1.3 bar	Dimension drawing M297100
Input pressure p_3, p_4, p_5, p_6	0.2...1.0 bar	Fitting instructions MV 7317

Accessories

-XMP Plug-in manometer for the *centair* measuring ranges; see Section 68.

1) See Section 60 on regulations concerning the quality of supply air, especially at low ambient temperature.

Operation

Refer to fitting instructions (MVE 7317).

Connection diagram

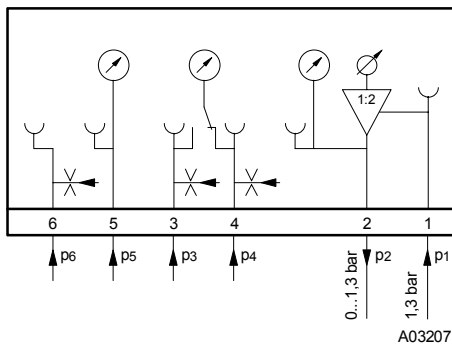

Dimension drawing

