

AK41...43 P: Pneumatic damper drive

For continuous or on/off control of air dampers, or similar, in ventilation and air-conditioning systems. The actuators of type AK41 and AK42 comply with EN 13463-1 and EN 1127-1 (Ex II 2 G T6) and can be employed in Zone 1 areas where there is a risk of explosion. Conforms to the regulations on pressure equipment (97/23/EG Art. 3.3).

Housing for AK41 and AK42 is of self-extinguishing plastic; AK43 is of light metal; membrane of silicon; drive spindle of stainless steel; Push-on nipple for connecting plastic tubing with internal diameter of 4 mm (AK41), compressed-air connection Rp 1/8, female thread (AK42, AK43).

Type	Operating range bar	Force at		Torque at		Permissible damper area ¹⁾ m ²	Weight kg
		0 bar N	1,2 bar Nm	0 bar Nm	1,2 bar Nm		
AK41 P1 F003	0.3...0.9	100	100	3	3	1	0.55
AK41 P2 F003	0.2...0.6	60	200	2	6	0.6	0.55
AK41 P3 F003	0.6...1.0	200	60	6	2	0.6	0.6
AK42 P F003	0.3...0.9	200	200	10	10	3	1.4
AK43 P F002	0.3...0.9	400	400	20	20	6	4.8

		AK41 P1	AK41 P2	AK41 P3	AK42 P	AK43 P
Control pressure ²⁾	bar	0...1.2	0...1.2	0...1.2	0...1.2	0...1.2
Max. pressure	bar	1.5	1.5	1.5	1.5	1.5
Stroke	mm	63	63	63	100	100
Effective area	cm ²	40	40	40	80	160
Length of lever for 90°	mm	44	44	44	70	70
Air consumption for 100% stroke	l _n	0.5	0.4	0.5	1.7	3.5
Running time for 100% stroke ³⁾	s	7	6	7	20	35
Permissible ambient temp. ⁴⁾	°C	-10...70	-10...70	-10...70	-10...70	-10...70
Expl. protection		yes	yes	yes	yes	no
Degree of protection		IP 20	IP 20	IP 20	IP 20	IP 20
Dimension drawing		M274941	M274941	M274941	M274942	M274943
Fitting instructions		MV 505518	MV 505518	MV 505518	MV 505519	MV 505520

Accessories

- XSP 31 Positioner (see Section 79)
- XAP 1 Aux. contact unit (see Section 79)
- XAP 2 Potentiometer unit (see Section 79)
- 0274354 000*** Rod, 600 mm long, Ø 10 mm, with ball joint
- 0370059 000*** Clamp-on lever for shaft Ø 8...18 mm
- Accessories for AK41 and AK42
- 0226518 003** Material for fitting XAP to AK41
- 0226519 003** Material for fitting XAP to AK42
- 0226521 002** Material for fitting XSP 31 to AK41
- 0226522 002** Material for fitting XSP 31 to AK42
- 0274586 000*** Straight ball joint with 2 nuts (M8) for fitting XSP 31 to AK4
- 0274587 000*** Fixing bracket for AK41
- 0274589 000*** Straight ball joint with 2 nuts (M8) for AK41
- 0274591 000*** Fixing bracket with screw Ø 5.5 × 13 (4×) for AK4
- 0274593 000*** Angled ball joint with 2 nuts (M8)
- 0274595 000*** Fixing console with screw (M8 × 30)
- 0274597 000*** Adaptor with nut (M8)
- 0370039 000*** Coupling nut with two locking nuts (M8)
- 0370040 000*** Rod with thread (M8) 500 mm long
- Accessories for AK43
- 0226520 003** Material for XAP
- 0226523 002** Material for XSP 31
- 0274596 000*** Fixing console with screw (M10 × 40)
- 0274598 000*** Adaptor with nut (M10)
- 0274605 000*** Angled ball joint with 2 nuts (M10)

¹⁾ Dimension drawing or wiring diagram are available under the same number

- 1) Recommended value for equal-sided, smooth-action air dampers. When tight-sealing dampers (as per DIN 1946) are used, the increased actuating power needed to overcome the louvre seals must be taken into account.
- 2) Needed in order to attain the actuating power.
See Section 60 on regulations concerning the quality of supply air, especially at lower ambient temperatures.
- 3) Based on the Centair air capacity (400 l_v/h) and a line of 20 m length and 4 mm diameter
- 4) Down to -20 °C for short periods when used in fresh-air ducts



T07753



Y07550

AK41...43 P

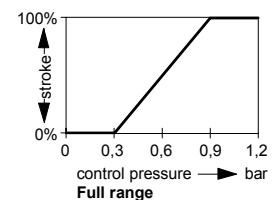

B00969

AK41 P2

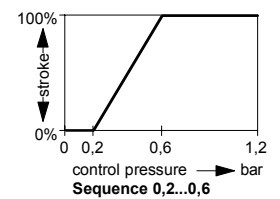

B00976

AK41 P3

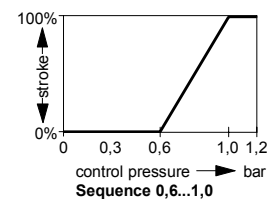

B00977

Operation

As the control pressure rises, the valve spindle extends; as the pressure falls, the spindle is retracted by the return spring. In order to attain the maximum actuating power at 0 and 100% stroke, the control pressure must change from 0 to 1.2 bar.

Fitting position

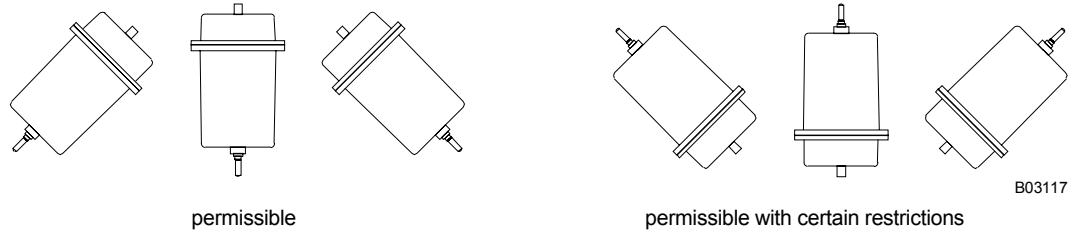

The ingress of condensate, drips etc. along the spindle and into the drive should be avoided

Fitting methods

In all the examples, XAP 1 and/or XAP 2 can be also be fitted onto the drives. The XSP 31 can be fitted only in the examples shown: see pages 4 - 6.

Dimension drawings

AK41 P

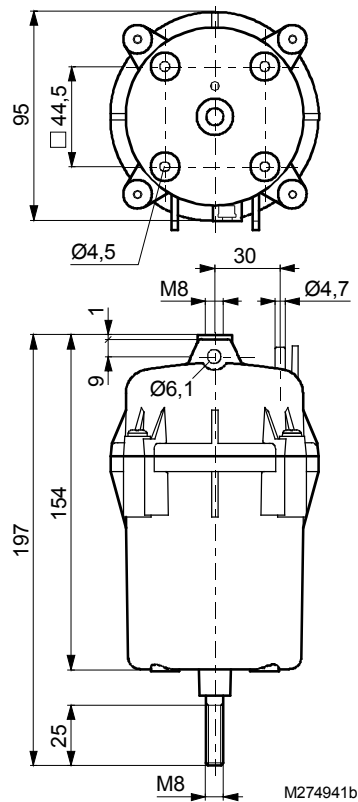

AK42 P

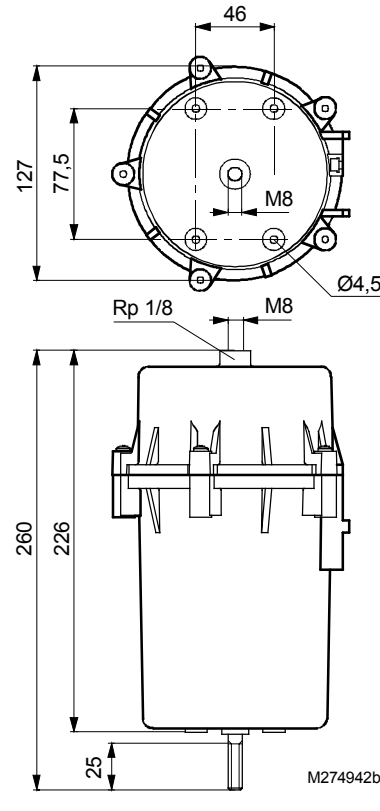

AK43 P

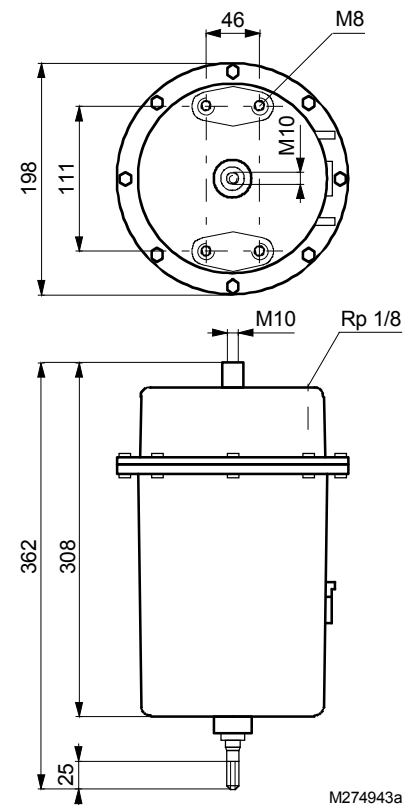

Accessories

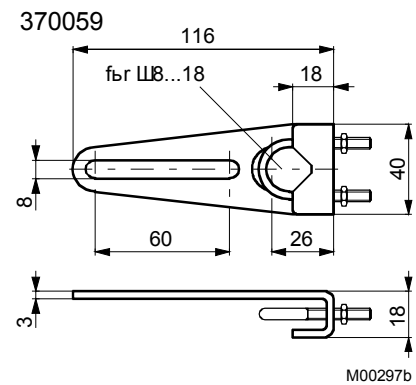
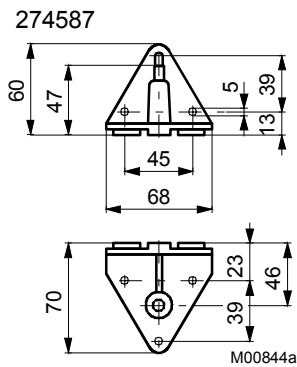
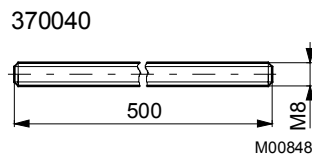
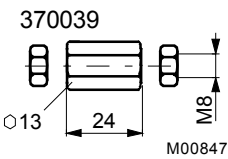
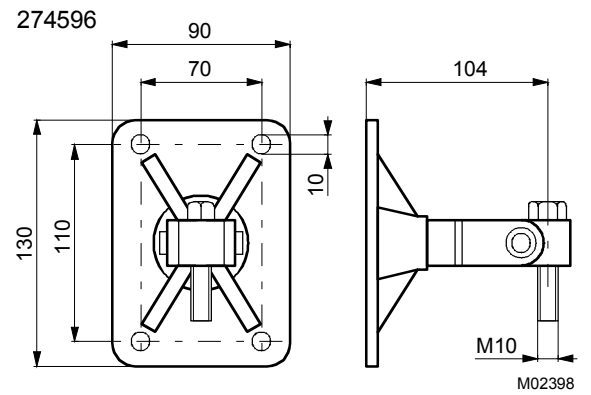
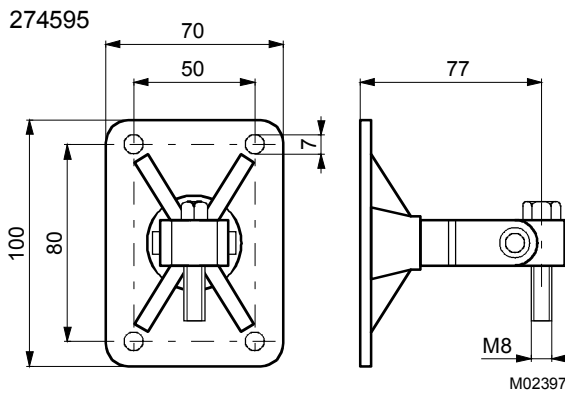
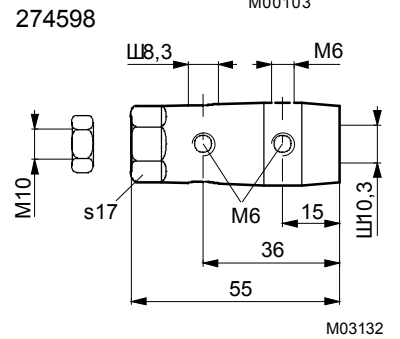
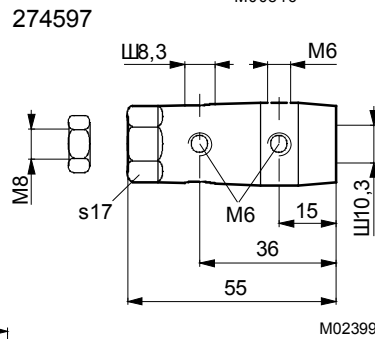
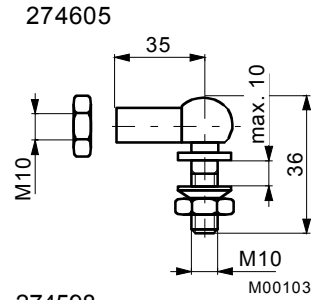
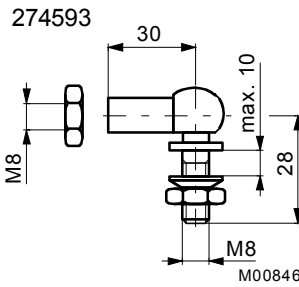
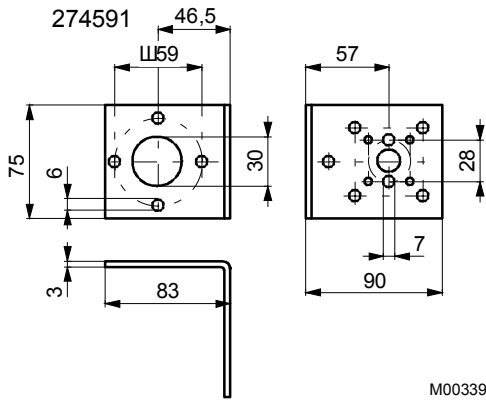
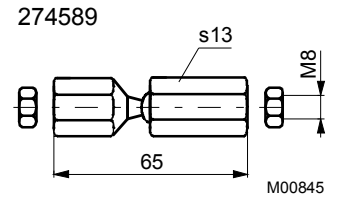
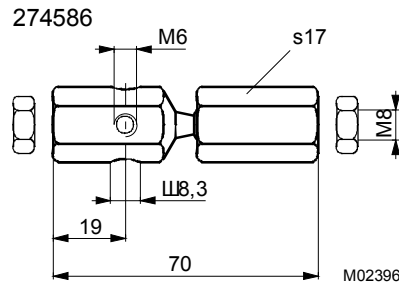
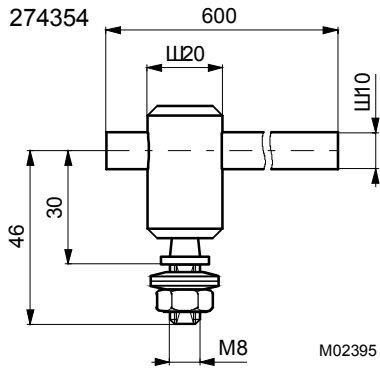

Fitting methods for AK41 P

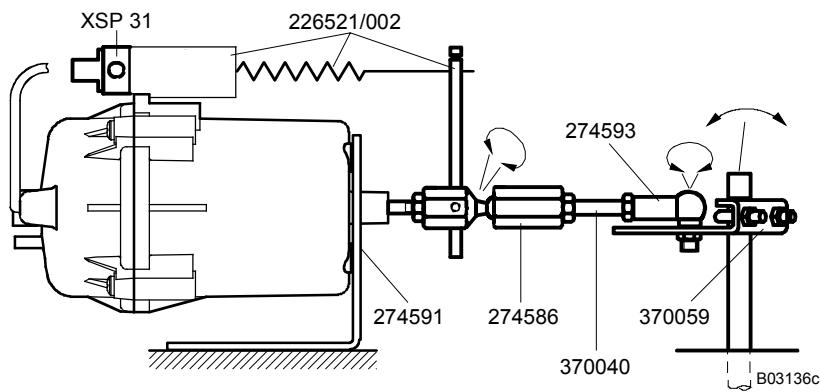
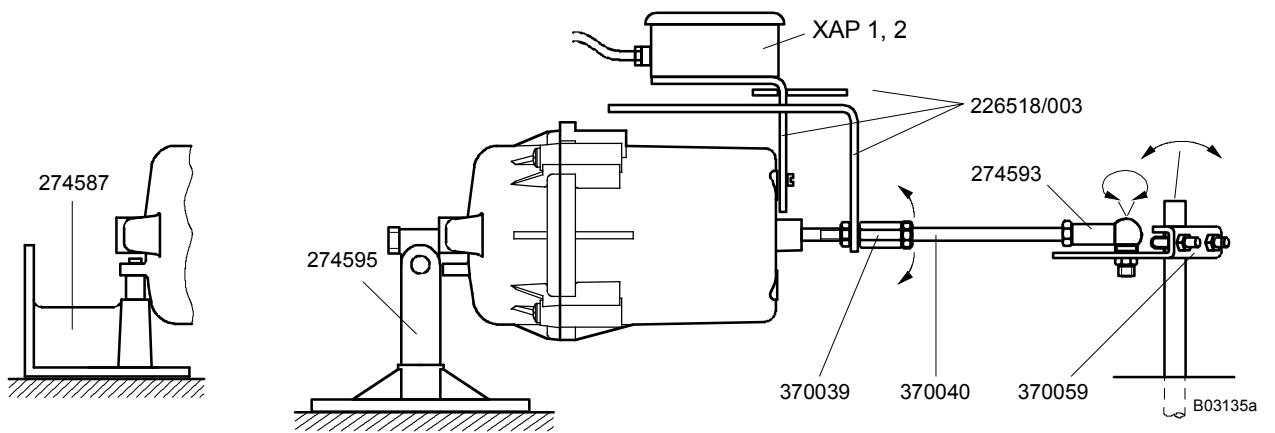
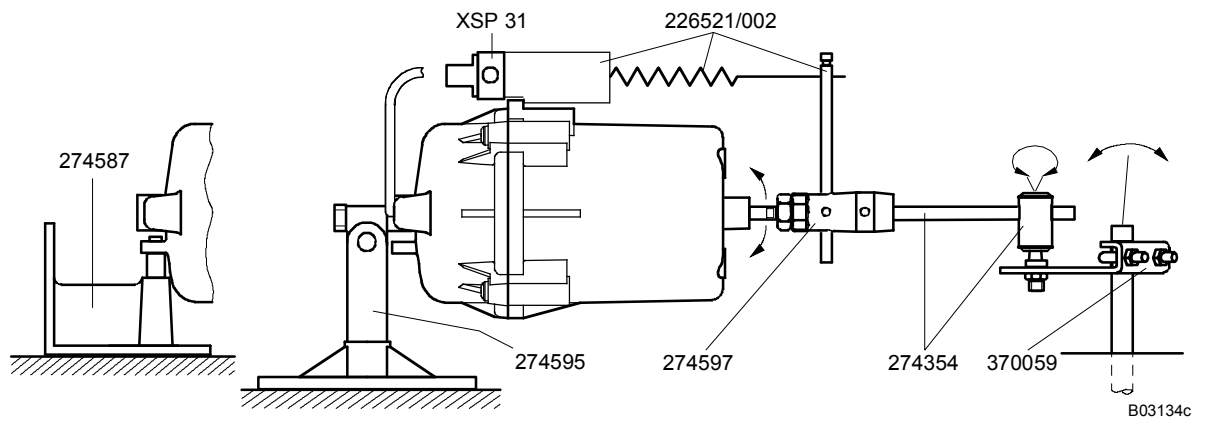
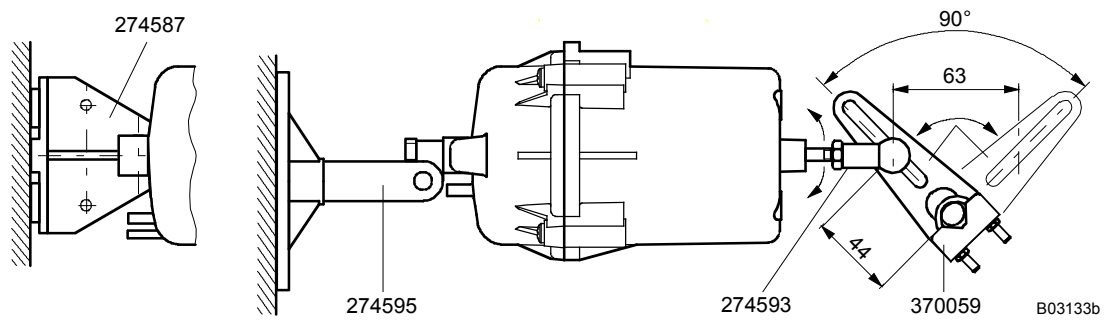

Fitting methods for AK41 P

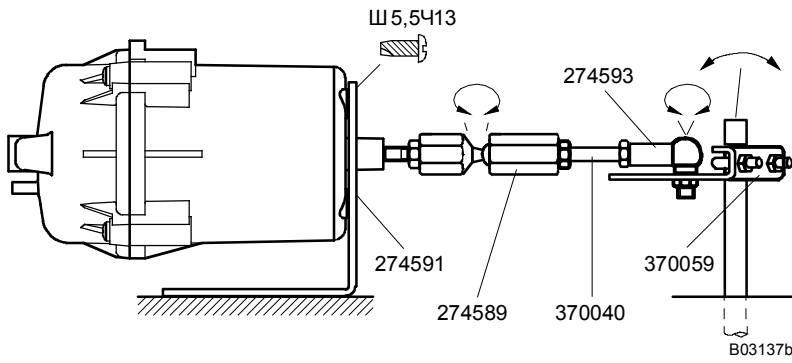

Fitting methods for AK42 P

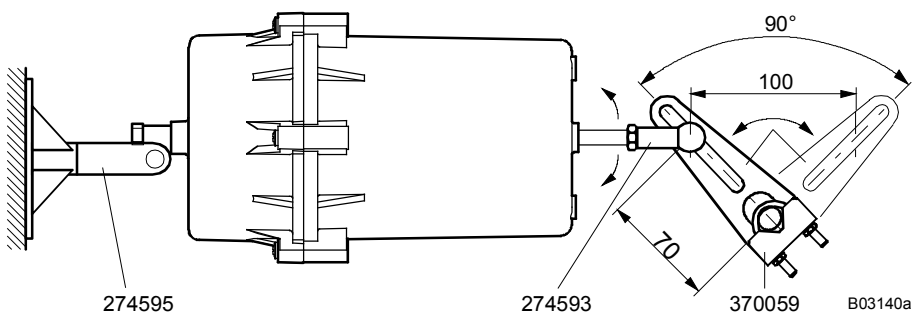
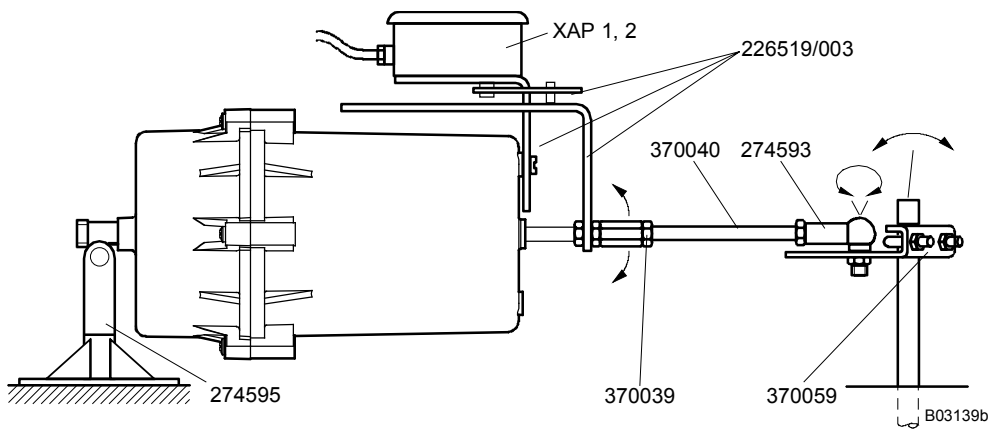
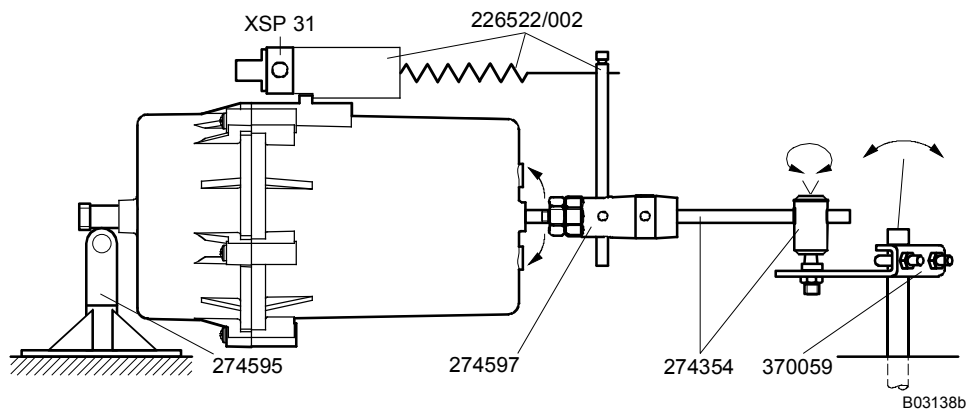

Fitting methods for AK43 P

